

Asynchronous Serial Interfaces and the Internet of Things

Lecture 12

Josh Brake
Harvey Mudd College

Outline

- Serial Interfaces pt. 2 – the Universal Synchronous/Asynchronous Receiver Transmitter
- General Internet Architecture
 - Protocol layers
 - Browsing the Web
 - HTTP - Commands and Format
 - HTML - Hypertext Markup Language
- ESP8266
 - Overview
 - Webserver Code
 - Basic workflow for whole system

Learning Objectives

By the end of this lecture you should be able to...

- Articulate the differences and tradeoffs between a synchronous serial link (e.g., SPI) and an asynchronous serial link.
- Use the USART peripheral on the MCU to print to the terminal window
- Write a basic HTML webpage.
- Explain the basic operating principles of an HTTP webserver.

Universal Synchronous/Asynchronous Receiver Transmitter (USART)

What if we don't want a shared clock?

We must...

- Agree on shared data rate
- Sample the incoming data stream at higher frequency to synchronize the input data stream with the reading circuitry
- Add additional bits at the beginning and end of the transmission to signal the bounds of the transmission

Q: What are some downsides of an asynchronous serial interface as compared to a synchronous one?

- Reduced **maximum transmission frequency** (typically 8x-16x overhead from sampling)
- Wasted **bits** in each transmission

USART Data Frame

4 components

1. Start bit: always logical 0
2. Data bits: 5-9 bits of data
3. Parity bit: Option bit with parity of data (i.e., even or odd. Simple error checking)
4. Stop bit(s): 1-2 bits. Always logical 1.

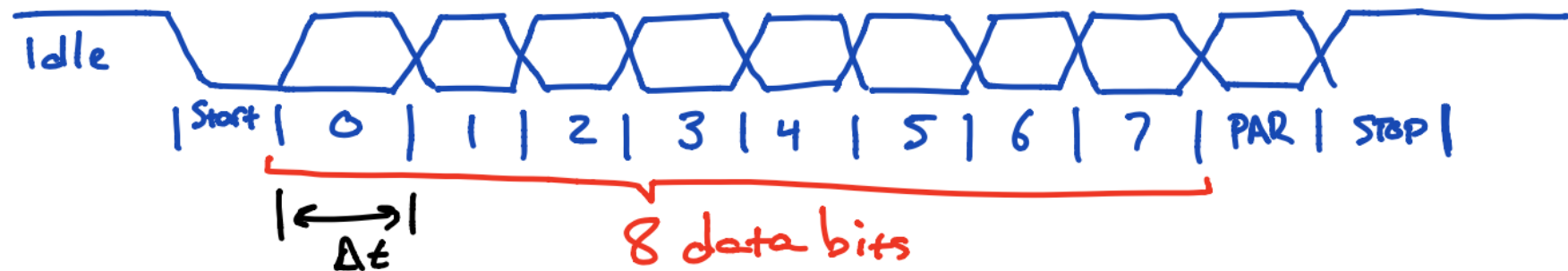

$$\text{Baud rate} = \frac{1}{\Delta t}$$

STM32L432KC USART

Figure 382. USART block diagram

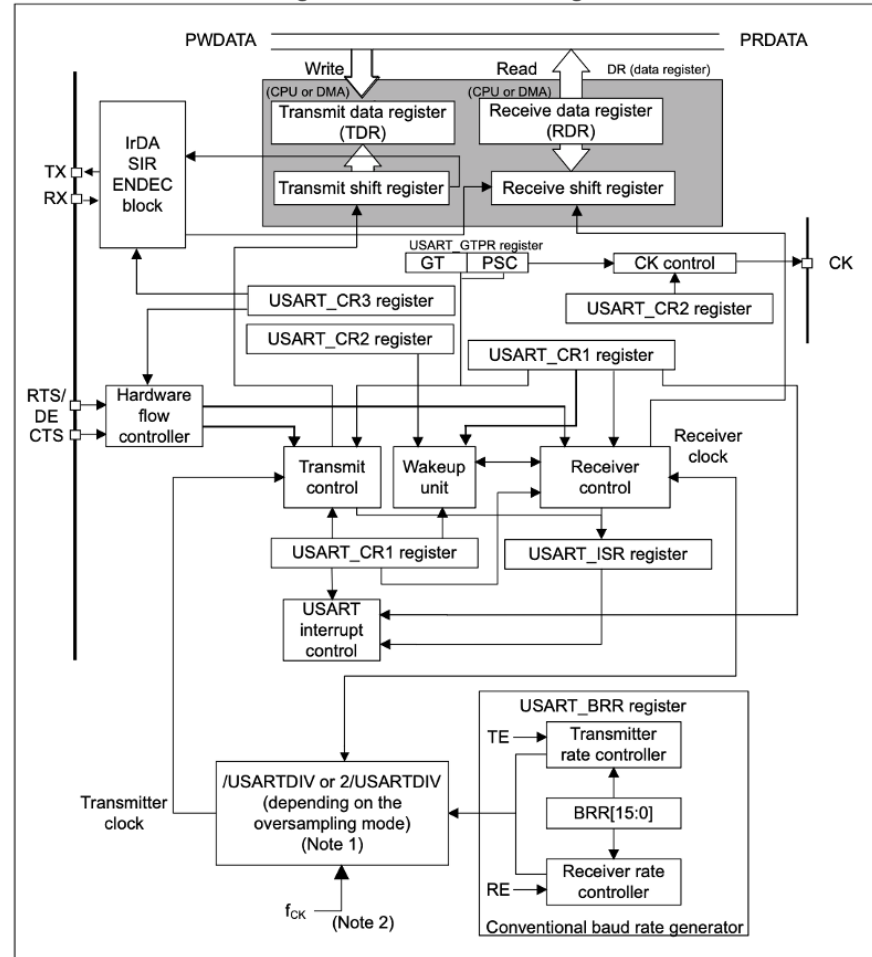

Data Registers

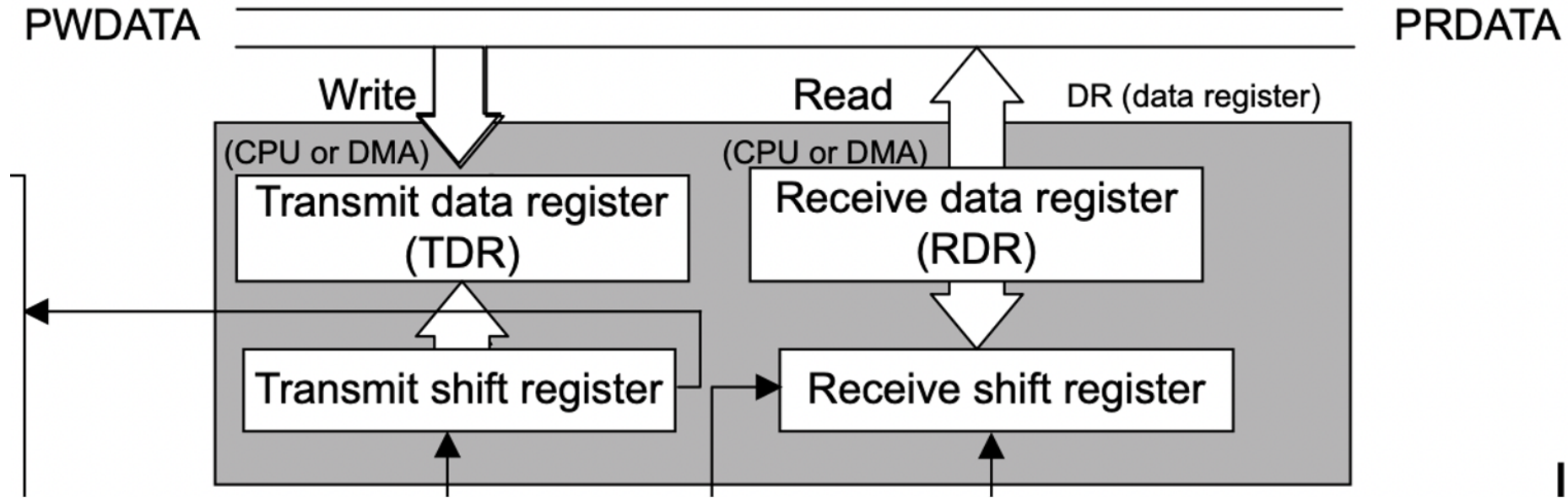

RM0394 p. 1198

Pins

- TX – transmitted data out from USART
- RX – received data in to USART
- CK – (optional) clock output for synchronous mode
- RTS – Request To Send indicates the USART is ready to receive data (when low)
- CTS – Clear To Send block data transmission at the end of the current transfer when high

Data framing

Data framing

Figure 384. Configurable stop bits

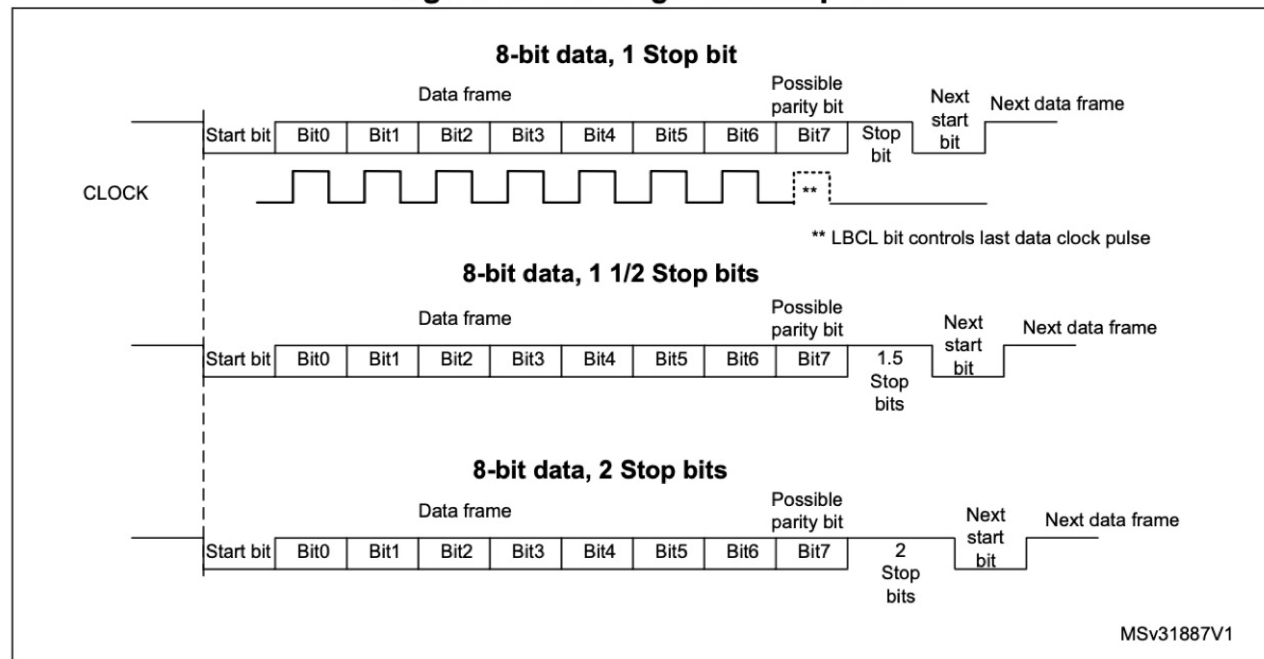

RM0394 p. 1202

9

RM0394 p. 1202

Error Flags

- Overrun – new byte in the **holding reg** before the old one was read out
- Frame – didn't get the **stop bit(s)** we expected
- Parity – calculated **parity** doesn't match **parity bit**.

Receiver

Figure 386. Start bit detection when oversampling by 16 or 8

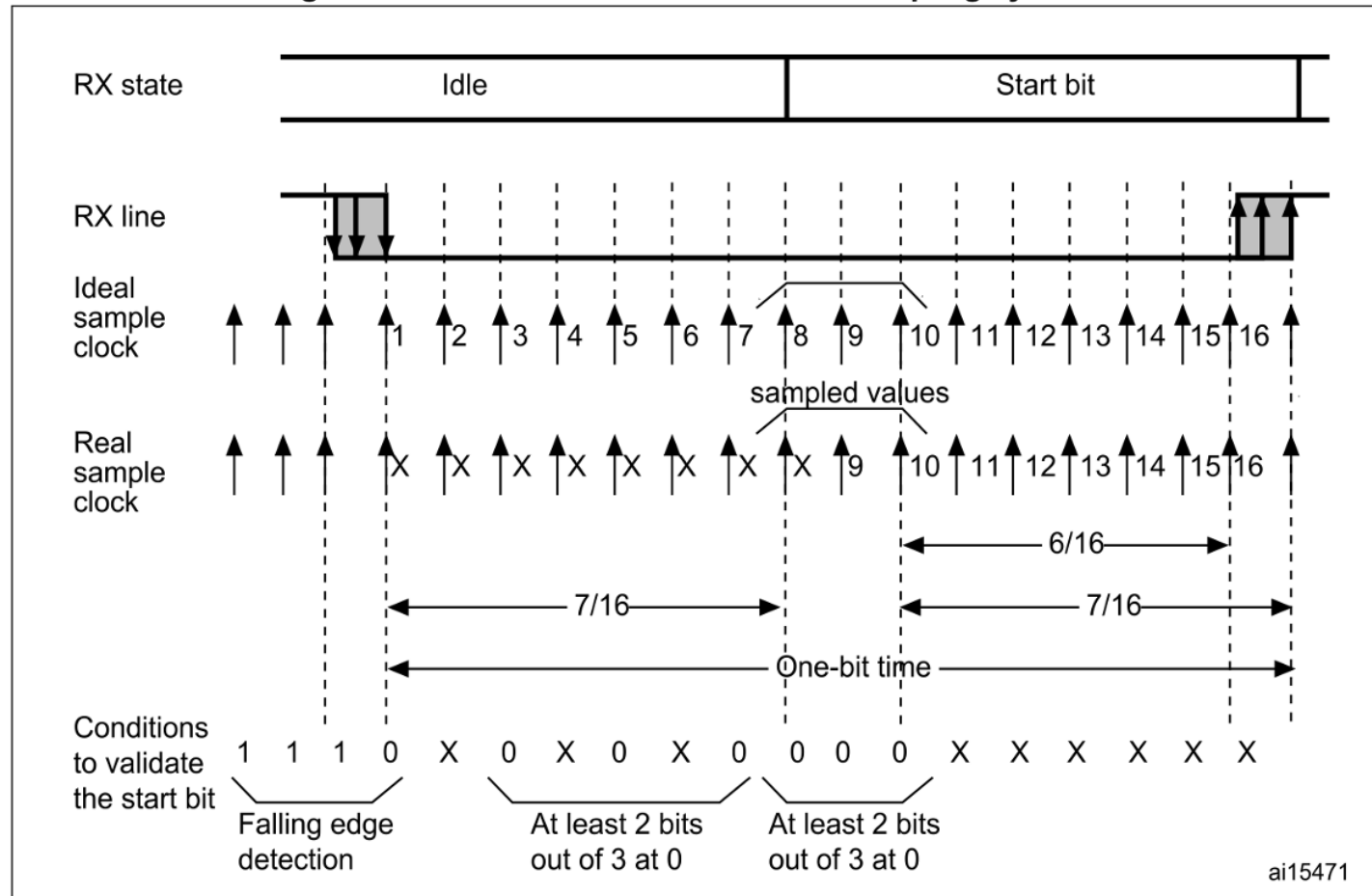

USART registers: Interrupt and Status Register (ISR)

UART Status Register

- **TXE** – transmit data register empty (0 if data is not transferred to the shift register, 1 if it is)
- **TC** – transmission complete flag
- **RXNE** – read data register not empty (0 if data has not been received, 1 if it is ready to be read)
- **FE** – framing error
- **PE** – parity error

38.8.8 Interrupt and status register (USART_ISR)

Address offset: 0x1C

Reset value: 0x0200 00C0

31	30	29	28	27	26	25	24	23	22	21	20	19	18	17	16
Res.	Res.	Res.	Res.	Res.	Res.	TCBGT	Res.	Res.	REACK	TEACK	WUF	RWU	SBKF	CMF	BUSY
						r			r	r	r	r	r	r	r
15	14	13	12	11	10	9	8	7	6	5	4	3	2	1	0
ABRF	ABRE	Res.	EOBF	RTOF	CTS	CTSIF	LBDF	TXE	TC	RXNE	IDLE	ORE	NF	FE	PE
r	r		r	r	r	r	r	r	r	r	r	r	r	r	r

USART registers: Data Register

- Used for both reads and writes
- Max 9-bit data value `DR[8:0]`

USART registers: Baud Rate Register

38.8.4 Baud rate register (USART_BRR)

This register can only be written when the USART is disabled (UE=0). It may be automatically updated by hardware in auto baud rate detection mode.

Address offset: 0x0C

Reset value: 0x0000 0000

31	30	29	28	27	26	25	24	23	22	21	20	19	18	17	16
Res.	Res.	Res.	Res.	Res.	Res.	Res.	Res.	Res.	Res.	Res.	Res.	Res.	Res.	Res.	Res.
15	14	13	12	11	10	9	8	7	6	5	4	3	2	1	0
BRR[15:0]															
rw	rw	rw	rw	rw	rw	rw	rw	rw	rw	rw	rw	rw	rw	rw	rw

Bits 31:16 Reserved, must be kept at reset value.

Bits 15:4 **BRR[15:4]**

$BRR[15:4] = USARTDIV[15:4]$

Bits 3:0 **BRR[3:0]**

When $OVER8 = 0$, $BRR[3:0] = USARTDIV[3:0]$.

When $OVER8 = 1$:

$BRR[2:0] = USARTDIV[3:0]$ shifted 1 bit to the right.

$BRR[3]$ must be kept cleared.

USART registers: Control register 1

- **M**: word length 8 or 9 data bits
- **PCE**: parity control enable
- **TE**: transmitter enable
- **RE**: receiver enable

USART registers: Control register 2

- **STOP**: 2-bit field, number of stop bits (0.5, 1, or 2)
- Various clock control (if using in synchronous mode)

38.8.2 Control register 2 (USART_CR2)

Address offset: 0x04

Reset value: 0x0000 0000

31	30	29	28	27	26	25	24	23	22	21	20	19	18	17	16
ADD[7:4]				ADD[3:0]				RTOEN	ABRMOD[1:0]		ABREN	MSBFI RST	DATAINV	TXINV	RXINV
rw	rw	rw	rw	rw	rw	rw	rw	rw	rw	rw	rw	rw	rw	rw	rw
15	14	13	12	11	10	9	8	7	6	5	4	3	2	1	0
SWAP	LINEN	STOP[1:0]		CLKEN	CPOL	CPHA	LBCL	Res.	LBDIE	LBDL	ADDM7	Res.	Res.	Res.	Res.
rw	rw	rw	rw	rw	rw	rw	rw		rw	rw	rw				

Character Reception

1. Program the M bit in USART_CR1 to define word length
2. Program the sampling rate (x8 or x16) in USART_CR1
3. Program the number of stop bits in USART_CR2
4. (optional): Enable DMA
5. Select the desired baud rate in USART_BRR
6. Enable the USART with UE=1 in USART_CR1
7. Set the RE bit in USART_CR1

Wait for RXNE bit to go from 0 (no data received) to 1 (data received). Then, read out the data from the data register

USART Instances

Figure 1. STM32L432xx block diagram

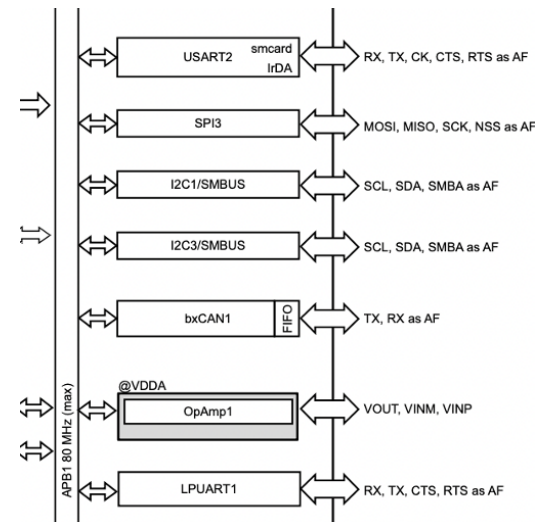
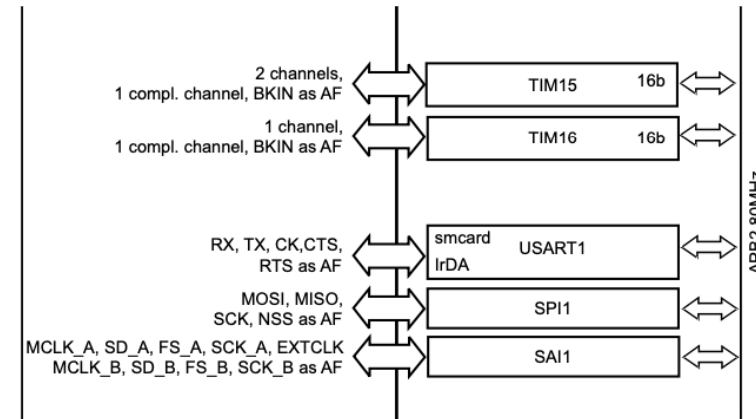
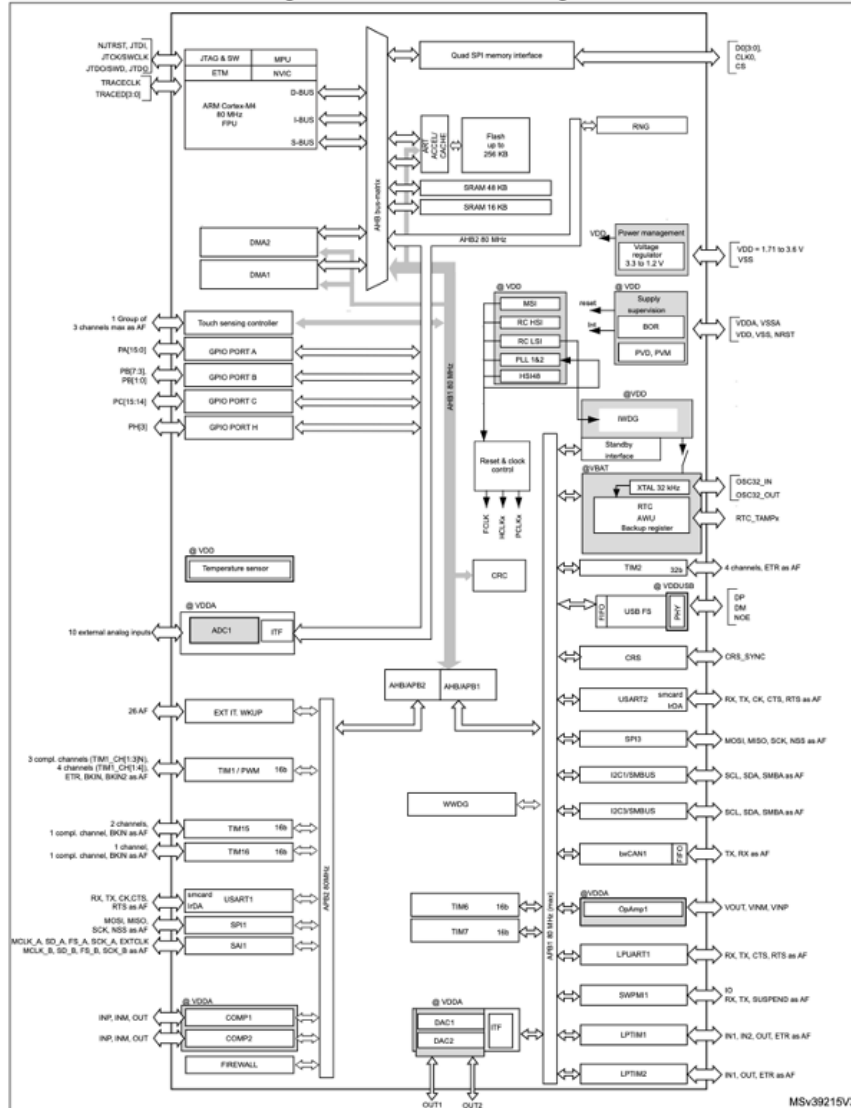

USART Activity

Activity

Configure the USART as an UART to transmit serial data

- Read user manual and develop a bullet list outline of how to configure the peripheral
- Write USART library
- Finish STM32L432KC_USART.h and STM32L432KC_USART.c.
- Configure in common 8N1 mode
 - 8 data bits
 - No parity bit
 - 1 stop bit
 - Operate at 9600 baud (9.6 Kbps)
 - UART is configured to use the HSI which is 16 MHz.
- Use simple main function to transmit a string of your choice over the UART.

Bits to configure

38.8.1 Control register 1 (USART_CR1)

Address offset: 0x00

Reset value: 0x0000 0000

31	30	29	28	27	26	25	24	23	22	21	20	19	18	17	16
Res.	Res.	Res.	M1	EOBIE	RTOIE	DEAT[4:0]				DEDT[4:0]					
			rw	rw	rw	rw	rw	rw	rw	rw	rw	rw	rw	rw	rw
15	14	13	12	11	10	9	8	7	6	5	4	3	2	1	0
OVER8	CMIE	MME	M0	WAKE	PCE	PS	PEIE	TXEIE	TCIE	RXNEIE	IDLEIE	TE	RE	UESM	UE
rw	rw	rw	rw	rw	rw	rw	rw	rw	rw	rw	rw	rw	rw	rw	rw

- UE: USART Enable
- M: Word Length
- OVER8: Oversampling mode
- TE: Transmitter Enable
- RE: Receiver Enable (In CR2)
- STOP: Number of stop bits

Setup

- Download source code from GitHub
- Create new SEGGER project
- Configure serial monitor to read at 9600 baud

Table 15. Alternate function AF0 to AF7⁽¹⁾

Port		AF0	AF1	AF2	AF3	AF4	AF5	AF6	AF7
		SYS_AF	TIM1/TIM2/ LPTIM1	TIM1/TIM2	USART2	I2C1/I2C2/I2C3	SPI1/SPI2	SPI3	USART1/ USART2/ USART3
Port A	PA0	-	TIM2_CH1	-	-	-	-	-	USART2_CTS
	PA1	-	TIM2_CH2	-	-	I2C1_SMBA	SPI1_SCK	-	USART2_RTS_ DE
	PA2	-	TIM2_CH3	-	-	-	-	-	USART2_TX
	PA3	-	TIM2_CH4	-	-	-	-	-	USART2_RX
	PA4	-	-	-	-	-	SPI1_NSS	SPI3_NSS	USART2_CK
	PA5	-	TIM2_CH1	TIM2_ETR	-	-	SPI1_SCK	-	-
	PA6	-	TIM1_BKIN	-	-	-	SPI1_MISO	COMP1_OUT	USART3_CTS
	PA7	-	TIM1_CH1N	-	-	I2C3_SCL	SPI1_MOSI	-	-
	PA8	MCO	TIM1_CH1	-	-	-	-	-	USART1_CK
	PA9	-	TIM1_CH2	-	-	I2C1_SCL	-	-	USART1_TX
	PA10	-	TIM1_CH3	-	-	I2C1_SDA	-	-	USART1_RX
	PA11	-	TIM1_CH4	TIM1_BKIN2	-	-	SPI1_MISO	COMP1_OUT	USART1_CTS
	PA12	-	TIM1_ETR	-	-	-	SPI1_MOSI	-	USART1_RTS_ DE
	PA13	JTMS-SWDIO	IR_OUT	-	-	-	-	-	-
	PA14	JTCK-SWCLK	LPTIM1_OUT	-	-	I2C1_SMBA	-	-	-
PA15	JTDI	TIM2_CH1	TIM2_ETR	USART2_RX	-	SPI1_NSS	SPI3_NSS	USART3_RTS_ DE	

USART2 Wiring on Nucleo-32

6.9 USART virtual communication

Thanks to SB2 and SB3, the USART interface of STM32 available on PA2 (TX) and PA15 (RX), can be connected to ST-LINK/V2-1. When USART is not used it is possible to use PA2 as Arduino Nano A7. Refer to [Table 7](#).

Table 7. Virtual communication configuration

Bridge	State ⁽¹⁾	Description
SB2	OFF	PA2 is connected to CN4 pin 5 as Arduino Nano analog input A7 and disconnected from ST-LINK USART.
	ON	PA2 is connected to ST-LINK as virtual Com TX (default).
SB3	OFF	PA15 is not connected.
	ON	PA15 is connected to ST-LINK as virtual Com RX (default).

1. The default configuration is reported in bold style.

USART2 Wiring

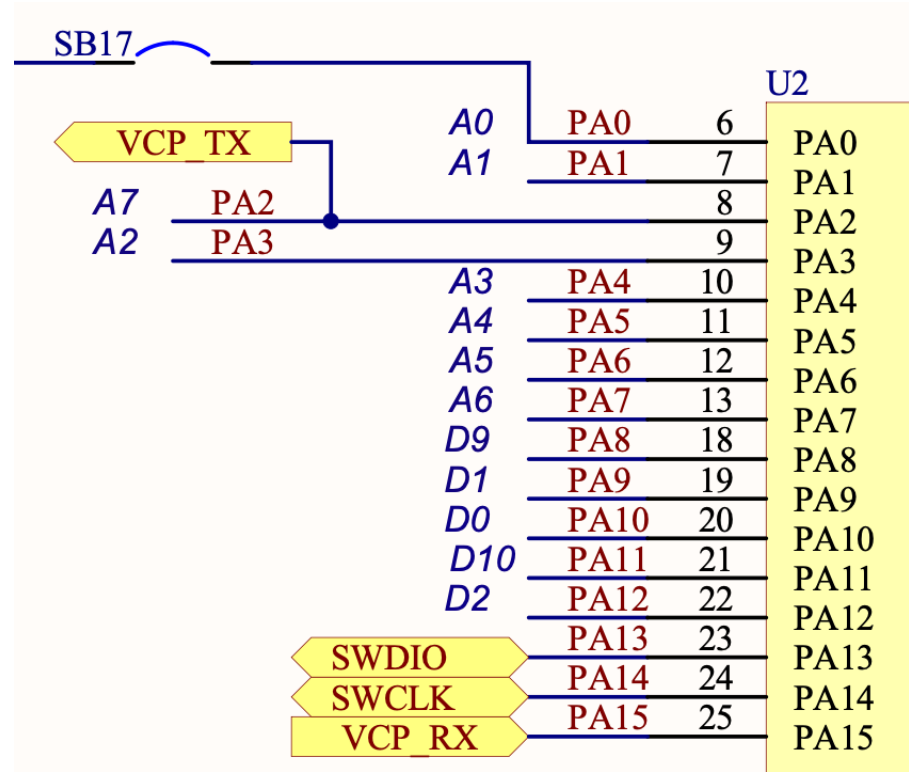
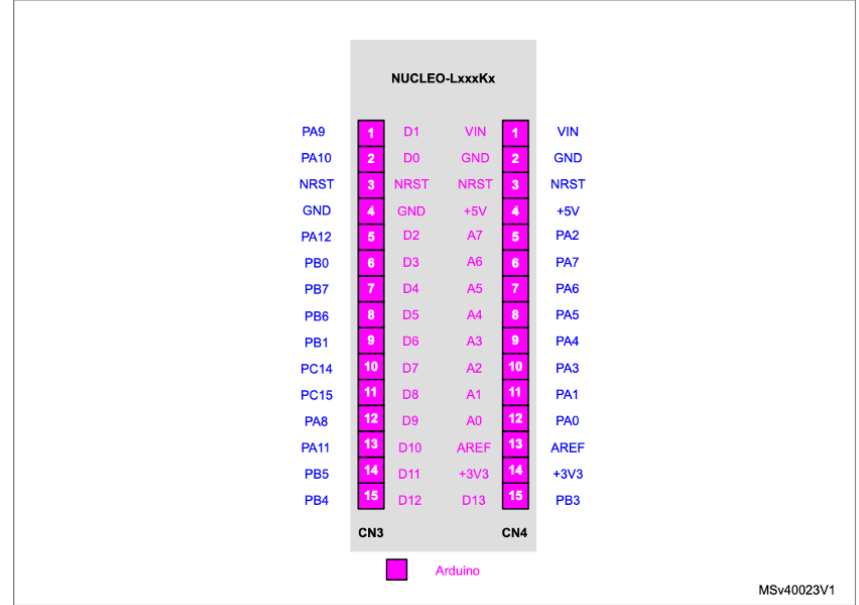

Figure 8. NUCLEO-L011K4, NUCLEO-L031K6, NUCLEO-L412KB and NUCLEO-L432KC pin assignment



UM1956 p. 33

Receiving Serial Input over USB

Use built-in serial monitor in SES

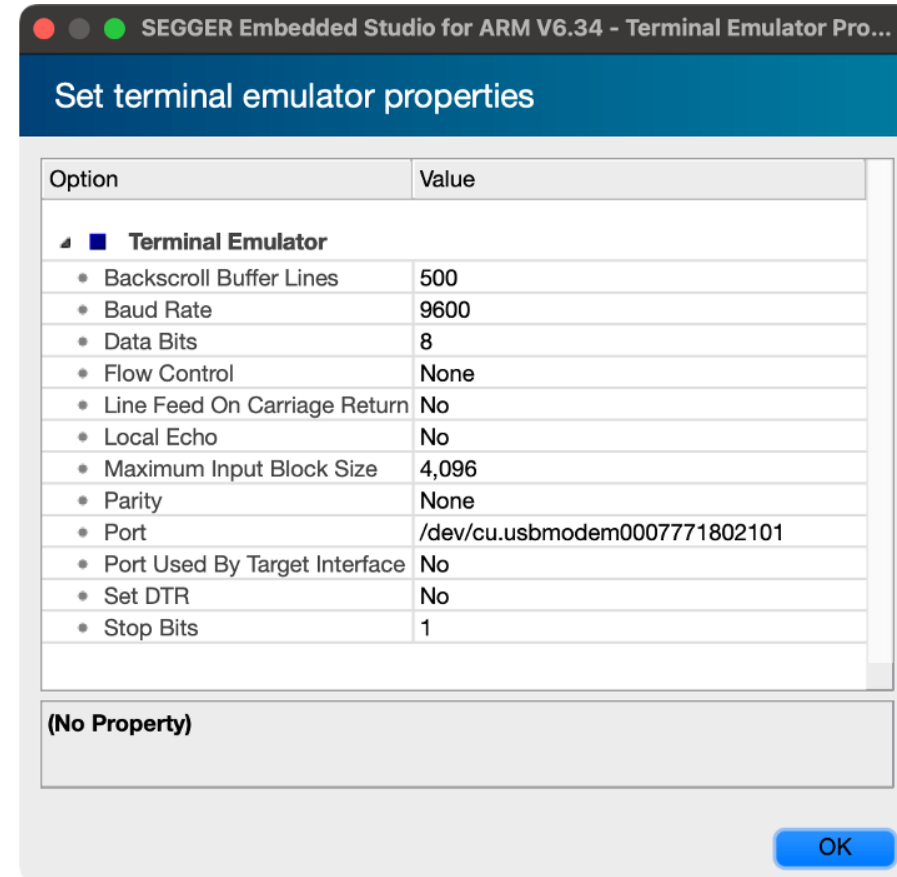
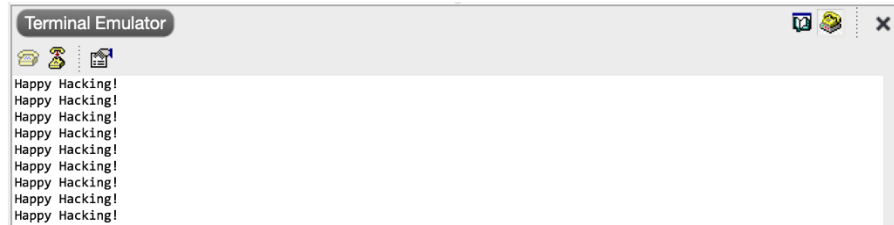

Solution

```
1  ...
2  // Set M = 00
3  // M=00 corresponds to 1 start bit, 8 data bits, n stop bits
4  USART->CR1 &= ~(USART_CR1_M0 | USART_CR1_M1);
5  // Set to 16 times sampling freq
6  USART->CR1 &= ~USART_CR1_OVER8;
7  // 0b00 corresponds to 1 stop bit
8  USART->CR2 &= ~USART_CR2_STOP;
9
10
11 // Set baud rate to 115200 (see RM 38.5.4 for details)
12 // Tx/Rx baud = f_CK/USARTDIV (since oversampling by 16)
13 // f_CK = 16 MHz (HSI)
14
15 USART->BRR = (uint16_t) (HSI_FREQ / baud_rate);
16 // Enable USART
17 USART->CR1 |= USART_CR1_UE;
18 // Enable transmission and reception
19 USART->CR1 |= USART_CR1_TE | USART_CR1_RE;
20
21 return USART;
22 }
```

Solution

```
1 void sendChar(USART_TypeDef * USART, char data){
2   while(!(USART->ISR & USART_ISR_TXE));
3   USART->TDR = data;
4   while(!(USART->ISR & USART_ISR_TC));
5 }
```

Solution

```
1 // Lecture 12 Demo
2 // Josh Brake
3 // jbrake@hmc.edu
4 // 10/5/22
5
6 #include "STM32L432KC.h"
7 #include <stm32l432xx.h>
8 #define USART_ID USART2_ID
9 #define TIM TIM15
10
11 int main(void) {
12 // Configure flash and clock
13 configureFlash();
14 configureClock();
15
16 ...
```

Solution

```
1 ...
2 // Initialize USART
3 USART_TypeDef * USART = initUSART(USART_ID, 9600);
4
5 // Initialize timer
6 RCC->APB2ENR |= RCC_APB2ENR_TIM15EN;
7 initTIM(TIM);
8
9 char msg[28] = "Happy Hacking!\n\r";
10
11 while(1){
12     int i = 0;
13     do {
14         sendChar(USART, msg[i]);
15         i += 1;
16     } while (msg[i]);
17     delay_millis(TIM, 2000);
18 }
19 }
```

The Hypertext Transfer Protocol (HTTP)

Protocol Layers

IP - Internet Protocol Address



TCP: Transmission Control Prot.
IP: Internet Protocol
Hardware: Network card, modem, etc.

- Worldwide web is a service on the Internet
- Uses Hypertext Transfer Protocol (HTTP)
 - What layer is this protocol at?
- URL: Uniform Resource Locator
 - URL format: `<protocol>://<hostname>:
<port>/<path_and_filename>`

Browsing the Web

What happens when you type in a URL?

- Finds IP for domain if necessary (Using Dynamic Nameserver (DNS))
- Connects to server, send HTTP request
- Server receives request, searches for desired page.
 - If it exists, sends it.
 - If not, sends 404 “Page Not Found” error code.
- Web browser gets page, closes connection
- Parses webpage sending HTTP requests as necessary to get all the elements

HTTP: Commands and Format

GET

- Most common
- Used to request a resource
- Format
 - `GET / HTTP/1.1 Host: Accept`

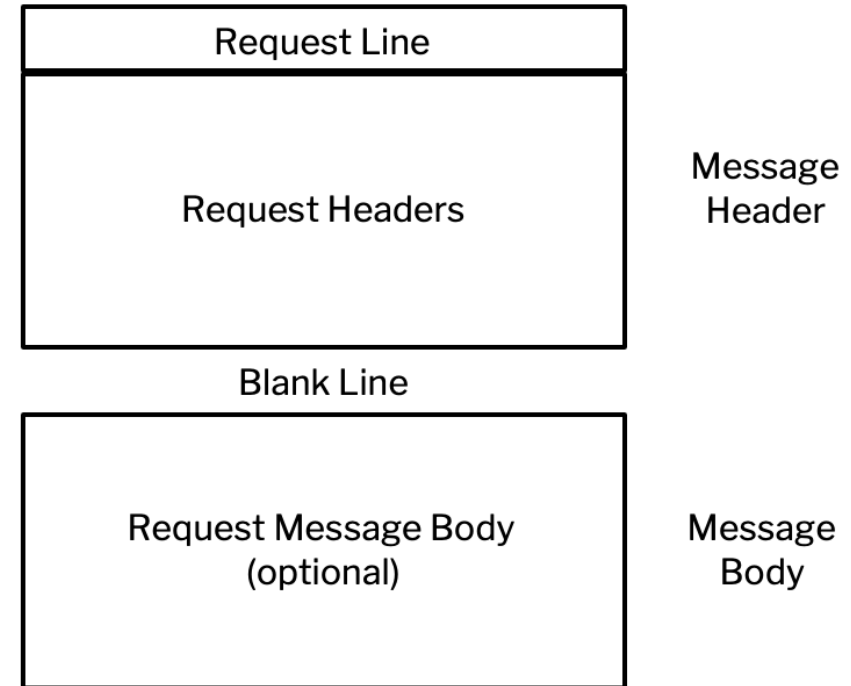

HTML: HyperText Markup Language

Simple text format to specify webpage formatting

- Elements
 - DOCTYPE statement
 - HTML tag
 - Head
 - Body
- Tags look like `<tag>...</tag>`
- Common tags: `html`, `head`, `body`, `p`, `h<x>` `x={1,2,3}`, `title`

Activity: Simple HTML Page

- Open text editor (e.g., VSCode)
- Save document as .html
- Create example webpage below
- Open in web browser

```
1 <!DOCTYPE html>
2 <head>
3   <title>My First Webpage</title>
4 </head>
5 <body>
6   <h1>E155 Demo</h1>
7   <p>Put text here!</p>
8 </body>
```

Other HTML Elements

- Other HTML elements
 - Form
 - Attributes
 - type - submit
 - action - where to send form data
 - value - text on button
- Add form to webpage

```
1 <form action="action_key">
2   <input type="submit" value="Send GET request">
3 </form>
```

ESP8266 Overview and Demo

Overview

ESP-WROOM-02 carries ESP8266EX highly integrated Wi-Fi SoC solution to meet the continuous demands for efficient power usage, compact design and reliable performance in the industry.

With the complete and self-contained Wi-Fi networking capabilities, it can perform as either a standalone application (WROOM module itself) or the slave to an MCU host which is the primary intention of the click board as a whole. So, this click board is applied to any microcontroller design as a Wi-Fi adaptor through UART interface (RX,TX lines on mikroBUS pin socket).

Notes	Pin	mikroBUS			Pin	Notes
	NC	1	AN	PWM	16	NC
HW Reset	RST	2	RST	INT	15	NC
Chip enable (active high)	EN	3	CS	TX	14	TX UART0_TXD / Transmit end in UART download (program) mode
	NC	4	SCK	RX	13	RX UART0_RXD / Receive end in UART download (program) mode
	NC	5	MISO	SCL	12	NC
	NC	6	MOSI	SDA	11	NC
Power supply	+3.3V	7	3.3V	5V	10	NC
Ground	GND	8	GND	GND	9	GND Ground



Overview

The Adafruit Huzzah ESP8266 breakout is what we designed to make working with this chip super easy and a lot of fun. We took a certified module with an onboard antenna, and plenty of pins, and soldered it onto our designed breakout PCBs. We added in: - Reset button, - User button that can also put the chip into bootloading mode, - Red LED you can blink, - Level shifting on the UART and reset pin, - 3.3V out, 500mA regulator (you'll want to assume the ESP8266 can draw up to - - 250mA so budget accordingly) - Two diode-protected power inputs (one for a USB cable, another for a battery)

Two parallel, breadboard-friendly breakouts on either side give you access to:

- 1 x Analog input (1.0V max)
- 9 x GPIO (3.3V logic), which can also be used for I2C or SPI
- 2 x UART pins
- 2 x 3-6V power inputs, reset, enable, LDO-disable, 3.3V output

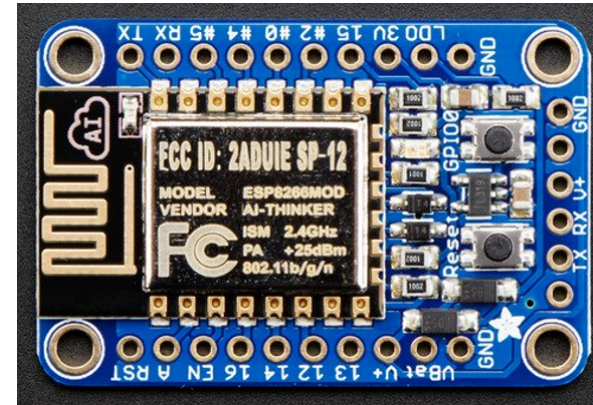

<https://cdn.sparkfun.com/datasheets/Wireless/WiFi/ESP8266ModuleV1.pdf>

ESP8266 Webserver Code

- Polls for waiting for a client to send an HTTP request
- When a request has been received, parses the request to slice the request after the /REQ: tag.
- Send the tag to the MCU which then decides what to do with the information.
- Then the MCU sends the content of the webpage back to the ESP8266 over the UART as properly formatted HTML.

ESP8266 Demo

Wireshark

The screenshot shows the Wireshark interface with a capture filter of `http && ip.addr==192.168.1.40`. The packet list pane shows several HTTP continuation packets and one GET request (No. 435595). The packet details pane shows the structure of the selected GET request, including Host, Connection, Upgrade-Insecure-Requests, Accept, User-Agent, and Referer. The packet bytes pane shows the raw hex and ASCII data of the request.

No.	Time	Source	Destination	Protocol	Length	Info
435613	8501.487211	192.168.1.40	192.168.1.124	HTTP	73	Continuation
435611	8501.417374	192.168.1.40	192.168.1.124	HTTP	126	Continuation
435609	8501.342990	192.168.1.40	192.168.1.124	HTTP	124	Continuation
435603	8501.271980	192.168.1.40	192.168.1.124	HTTP	90	Continuation
435601	8501.206040	192.168.1.40	192.168.1.124	HTTP	72	Continuation
435599	8501.140933	192.168.1.40	192.168.1.124	HTTP	83	Continuation
435595	8501.013972	192.168.1.124	192.168.1.40	HTTP	452	GET /REQ=OFF? HTTP/1.1
435552	8498.421552	192.168.1.40	192.168.1.124	HTTP	73	Continuation
435550	8498.352296	192.168.1.40	192.168.1.124	HTTP	126	Continuation
435548	8498.283938	192.168.1.40	192.168.1.124	HTTP	124	Continuation
435545	8498.206892	192.168.1.40	192.168.1.124	HTTP	90	Continuation
435543	8498.140880	192.168.1.40	192.168.1.124	HTTP	72	Continuation
435541	8498.078352	192.168.1.40	192.168.1.124	HTTP	83	Continuation

Host: 192.168.1.40\r\n
Connection: keep-alive\r\n
Upgrade-Insecure-Requests: 1\r\n
Accept: text/html,application/xhtml+xml,application/xml;q=0.9,*/*;q=0.8\r\n
User-Agent: Mozilla/5.0 (Macintosh; Intel Mac OS X 10_15_7) AppleWebKit/605.1.15 (KHTML, like Gecko) Version/14.0 Safari/605.1.15\r\n
Referer: http://192.168.1.40/REQ=ON?\r\n

0050 73 74 3a 20 31 39 32 2e 31 36 38 2e 31 2e 34 30 st: 192.168.1.40
0060 0d 0a 43 6f 6e 6e 65 63 74 69 6f 6e 3a 20 6b 65 ..Connec tion: ke
0070 65 70 2d 61 6c 69 76 65 0d 0a 55 70 67 72 61 64 ep-alive ..Upgrad
0080 65 2d 49 6e 73 65 63 75 72 65 2d 52 65 71 75 65 e-Insecu re-Reque
0090 73 74 73 3a 20 31 0d 0a 41 63 63 65 70 74 3a 20 sts: 1·
00a0 74 65 78 74 2f 68 74 6d 6c 2c 61 70 70 6c 69 63 text/htm l,applic
00b0 61 74 69 6f 6e 2f 78 68 74 6d 6c 2b 78 6d 6c 2c ation/xh tml+xml,
00c0 61 70 70 6c 69 63 61 74 69 6f 6e 2f 78 6d 6c 3b applicat ion/xml;
00d0 71 3d 30 2e 39 2c 2a 2f 2a 3b 71 3d 30 2e 38 0d q=0.9,*/*;q=0.8·
00e0 0a 55 73 65 72 2d 41 67 65 6e 74 3a 20 4d 6f 7a ·User-Ag ent: Moz
00f0 69 6c 6c 61 2f 35 2e 30 20 28 4d 61 63 69 6e 74 illa/5.0 (Macint
0100 6f 73 68 3b 20 49 6e 74 65 6c 20 4d 61 63 20 4f osh; Int el Mac O
0110 53 20 58 20 31 30 5f 31 35 5f 37 29 20 41 70 70 S X 10_1 5_7) App
0120 6c 65 57 65 62 4b 69 74 2f 36 30 35 2e 31 2e 31 leWebKit /605.1.1
0130 35 20 28 4b 48 54 4d 4c 2c 20 6c 69 6b 65 20 47 5 (KHTML , like G
0140 65 63 6b 6f 29 20 56 65 72 73 69 6f 6e 2f 31 34 ecko) Ve rsion/14
0150 2e 30 20 53 61 66 61 72 69 2f 36 30 35 2e 31 2e .0 Safar i/605.1.
0160 31 35 0d 0a 52 65 66 65 72 65 72 3a 20 68 74 74 15·Refe rer: htt
0170 70 3a 2f 2f 31 39 32 2e 31 36 38 2e 31 2e 34 30 p://192.168.1.40
0180 2f 52 45 51 3d 4f 4e 3f 0d 0a 41 63 63 65 70 74 /REQ=ON? ..Accept
0190 2d 4c 61 6e 67 75 61 67 65 3a 20 65 6e 2d 75 73 -Languag e: en-us
01a0 0d 0a 41 63 63 65 70 74 2d 45 6e 63 6f 64 69 6e ·Accept -Encodin
01b0 67 3a 20 67 7a 69 70 2c 20 64 65 66 6c 61 74 65 g: gzip, deflate
01c0 0d 0a 0d 0a

HTTP Referer (http.referer), 38 bytes

Packets: 484207 · Displayed: 887 (0.2%)

Profile: Default

Wrapup

- UART is a serial interface without a shared clock. Saves a wire, but at the cost of much slower data rates due to sampling overhead.
- Webpages in HTML are served using HTTP – sending text over a serial connection.